

# HURRICANE FR FIRE RATED VENTILATOR

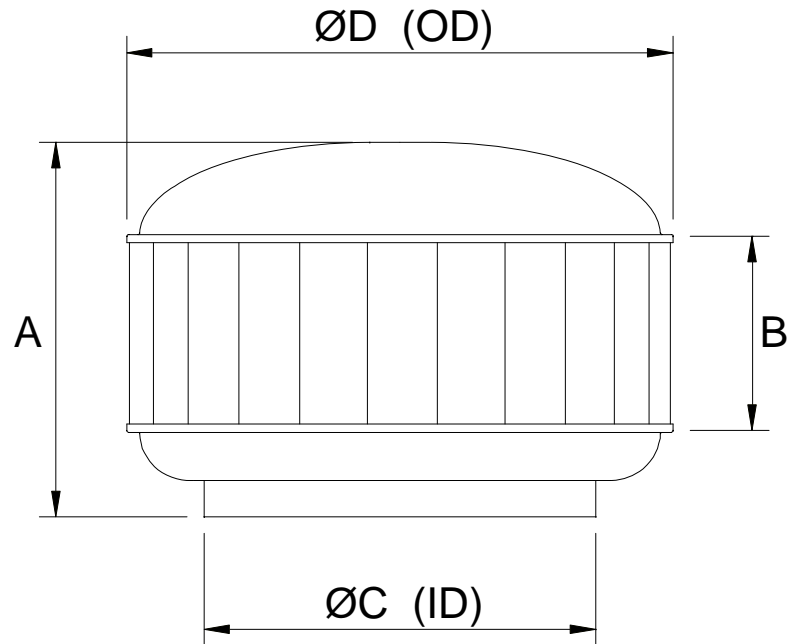

## DIMENSIONS:

MODEL	A (mm)	B (mm)	ØC (mm)	ØD (mm)	Throat Area (m <sup>2</sup> )	Weight (kg)
H900FR	643	400	897	1096	0.6319	18.3

Tolerances: Size +/- 2mm  
Weight +/- 0.1kg

## SPECIFICATIONS:

### MATERIAL:

Turbine & throat: Aluminium 5005 H34  
Dome & skirt: Aluminium 1200 H0  
Brackets: Aluminium 6060 T591  
Spider: Zinc passivate plated mild steel  
Shaft: 303 Stainless Steel

### ROTATION BEARINGS:

Main bearing holder assembly: Glass Reinforced Polyphenylene Sulfide (PPS)  
Main bearing: Double row ball bearing - BWF30-119Z  
Spider bearing (H600-H900 only): Single row ball bearing – AS204

### WIND SPEED RATING:

205.2km/h (57m/s) – Performance level 1  
(As per AS 4740:2000 Natural ventilators-Classification and performance)

### FIRE RATING:

Ability to operate for 120minutes at 200°C  
Ability to operate for 30minutes at 300°C

(As per AS 1668.1-1998 Section 4.8.1 The use of ventilation and airconditioning in buildings, Part 1: Fire and smoke control in multi-compartment buildings)